

# Sanyo DL8032-001 Laser Diode Specifications

The Sanyo DL8032-001 is a high-power laser diode with an optical output of 150mW and a typical operating wavelength of 830nm. The DL8032-001 has a Ø9mm package.

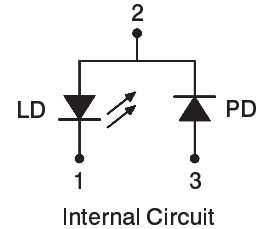

## Absolute Maximum Ratings (Tc=25 °C)

Characteristic	Symbol	Value	Unit
Optical output power	Po	150	mW
Laser diode reverse voltage	VR(LD)	2	V
Photodiode reverse voltage	VR(PD)	30	V
Operating temperature	Topr	- 10 to + 50	°C
Storage temperature	Tstg	- 40 to + 85	°C

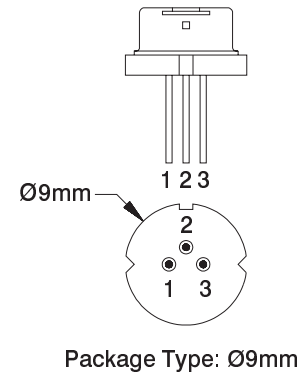

## Operating and Electrical Characteristics (Tc=25 °C)

Characteristic	Symbol	Min.	Typ.	Max.	Unit	Test Condition
Threshold current	I <sub>th</sub>	-	50	70	mA	-
Operating current	I <sub>op</sub>	-	185	220	mA	Po=150mW
Operating voltage	V <sub>op</sub>	-	1.8	2.2	V	Po=150mW
Lasing Wavelength	λ <sub>p</sub>	815	830	840	nm	Po=150mW
Beam divergence (parallel)	θ <sub>//</sub>	5	7	11	deg	Po=150mW, (FWHM)
Beam divergence (perpendicular)	θ <sub>⊥</sub>	12	18	25	deg	Po=150mW, (FWHM)
Differential efficiency	η	0.7	1.0	-	mW/mA	-
Monitor current	I <sub>m</sub>	0.15	0.5	2.0	mA	Po=150mW
Astigmatism	As	-	10	-	microns	Po=150mW

Disclaimer: The laser diode information summarized above is based on the respective diode manufacturer's commercial catalog and/or data sheet specifications. The data is presumed to be accurate; however, it is subject to change without notice. Optima makes no representation as to the accuracy of the information and does not assume any responsibility for errors or omissions contained herein. The user must refer to the manufacturers specifications for details concerning the intended application and operation, diode limitations, and safety.

**For current pricing and stock availability please contact:**

Optima Precision Inc. 775 SW Long Farm Road West Linn, Oregon 97068 U.S.A.  
 Phone: (503) 638-2525 Fax: (503) 638-4545 email: [optima@optima-optics.com](mailto:optima@optima-optics.com)  
 Website: <http://www.optima-optics.com>