

Sanyo DL3147-060 Laser Diode Specifications

The Sanyo DL3147-060 has a typical output of 650nm and an absolute maximum output of 7mW. The diode features low threshold current and extended temperature range for operation up to 5mW. Intended applications include optical disc storage products like DVD-ROM / Players and laser modules. The DL3147-060 has a Ø5.6mm package.

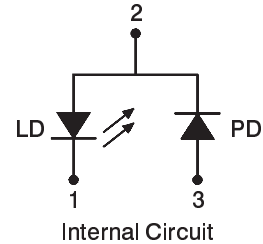

Absolute Maximum Ratings (Tc=25 °C)

Characteristic	Symbol	Value	Unit
Optical output power	Po	7	mW
Laser diode reverse voltage	VR(LD)	2	V
Photodiode reverse voltage	VR(PD)	30	V
Operating temperature	Topr	- 10 to + 70	°C
Storage temperature	Tstg	- 40 to + 85	°C

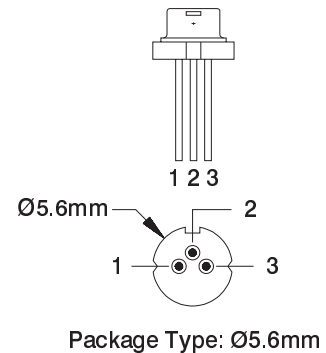

Operating and Electrical Characteristics (Tc=25 °C)

Characteristic	Symbol	Min.	Typ.	Max.	Unit	Test Condition
Threshold current	Ith	-	20	35	mA	CW
Operating current	Iop	-	30	45	mA	Po=5mW
Operating voltage	Vop	-	2.3	2.6	V	Po=5mW
Lasing Wavelength	λ_p	645	650	660	nm	Po=5mW
Beam divergence (parallel)	$\theta_{//}$	7	8	10	deg	Po=5mW, (FWHM)
Beam divergence (perpendicular)	θ_{\perp}	25	30	35	deg	Po=5mW, (FWHM)
Differential efficiency	dPo/dIop	0.3	0.5	0.8	mW/mA	-
Monitor current	I _m	0.08	0.2	0.4	mA	Po=5mW
Astigmatism	As	-	8	-	microns	Po=5mW

Disclaimer: The laser diode information summarized above is based on the respective diode manufacturer's commercial catalog and/or data sheet specifications. The data is presumed to be accurate; however, it is subject to change without notice. Optima makes no representation as to the accuracy of the information and does not assume any responsibility for errors or omissions contained herein. The user must refer to the manufacturers specifications for details concerning the intended application and operation, diode limitations, and safety.

For current pricing and stock availability please contact:

Optima Precision Inc. 775 SW Long Farm Road West Linn, Oregon 97068 U.S.A.
 Phone: (503) 638-2525 Fax: (503) 638-4545 email: optima@optima-optics.com
 Website: <http://www.optima-optics.com>