

REVISIONS				
ZONE	REV	DESCRIPTION	DATE	APPROVED

REV -
SHT 1
300-0340-780
DWG NO.

SCHEMATIC DIAGRAM:

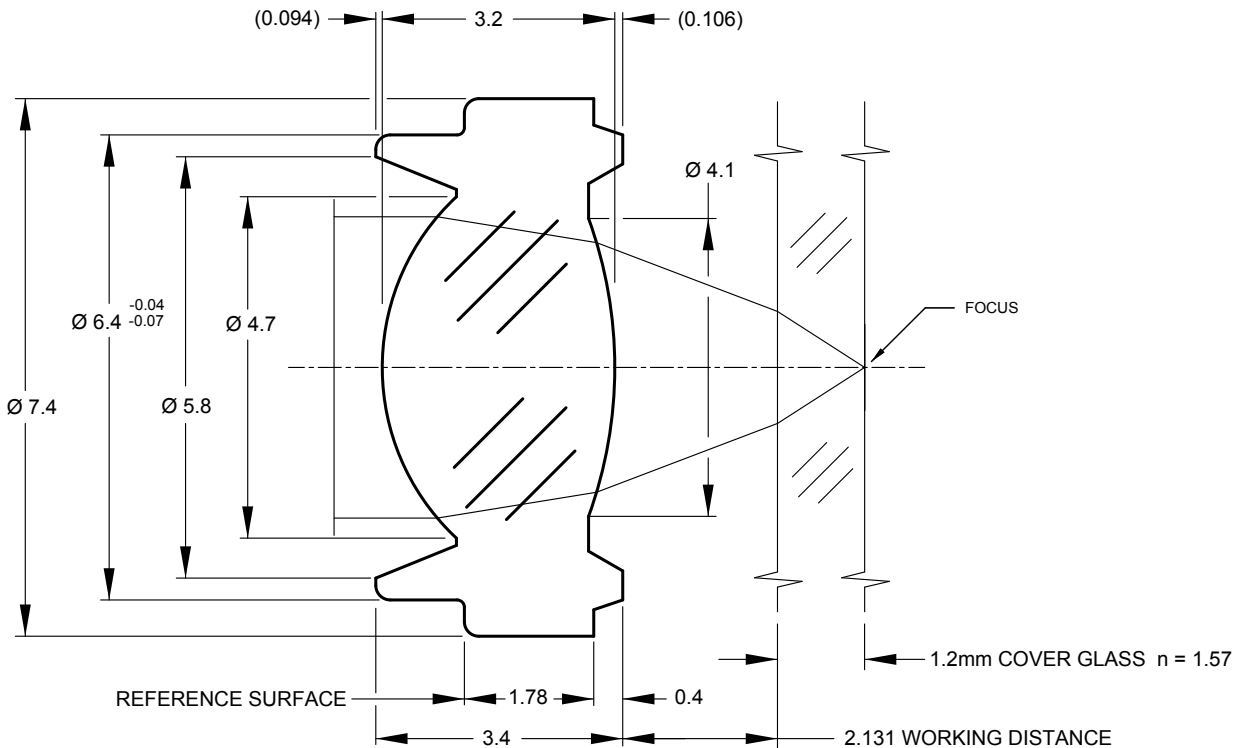

SPECIFICATIONS:

OBJECTIVE LENS, PLASTIC

1. WAVELENGTH: 780nm
2. FOCAL LENGTH: 3.851mm
3. NUMERICAL APERTURE: 0.54NA
4. CLEAR APERTURE: Ø 4.147mm
5. F#: 0.9
6. WORKING DISTANCE: 2.131mm
7. IMAGE/OBJECT DISTANCE: 31.18
8. TRANSMISSION: >97%
9. COVER GLASS THICKNESS: 1.2mm
10. COVER GLASS REFRACTIVE INDEX: 1.55
11. WEIGHT: <0.106 grams
12. WORKING TEMPERATURE: -10°C TO +65°C
13. TYPICAL WAVEFRONT ABERRATION
ON AXIS: <0.04 RMS @ 0.1mm IMAGE HEIGHT

AR COATING

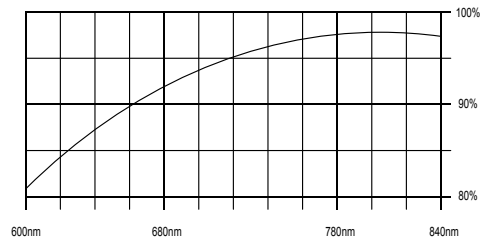

LENS TRANSMISSION VS. WAVELENGTH

NOTE: ALL DIMENSIONS ARE IN MILLIMETERS

CLASSIFICATION BASE LINE RELEASE	
CONTRACT/FILENAME 3000340.DWG	
DRAWN BY RS	DATE 15JAN15
APPROVED BY	DATE
GENERAL TOLERANCE: ±0.1	

OPTIMA PRECISION INC.			
ASPHERIC PLASTIC OBJECTIVE LENS			
A	FMSC NO	DRAWING NO 300-0340-780	REV --
SCALE 10x	011515	SHEET 1 OF 1	