

REVISIONS				
ZONE	REV	DESCRIPTION	DATE	APPROVED

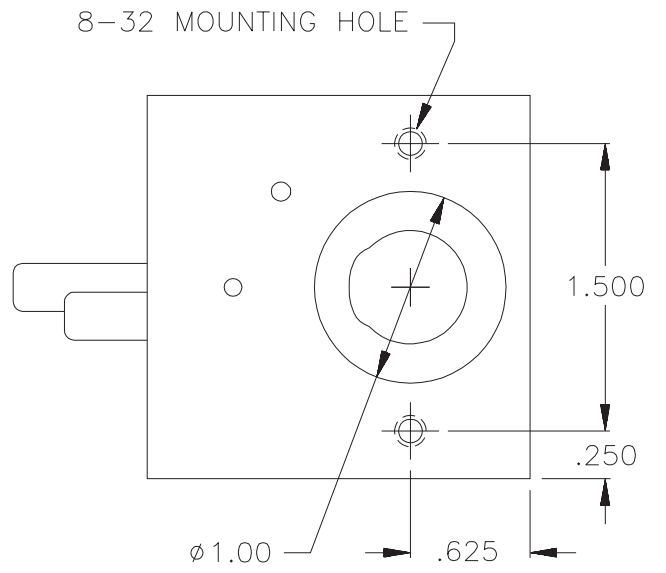
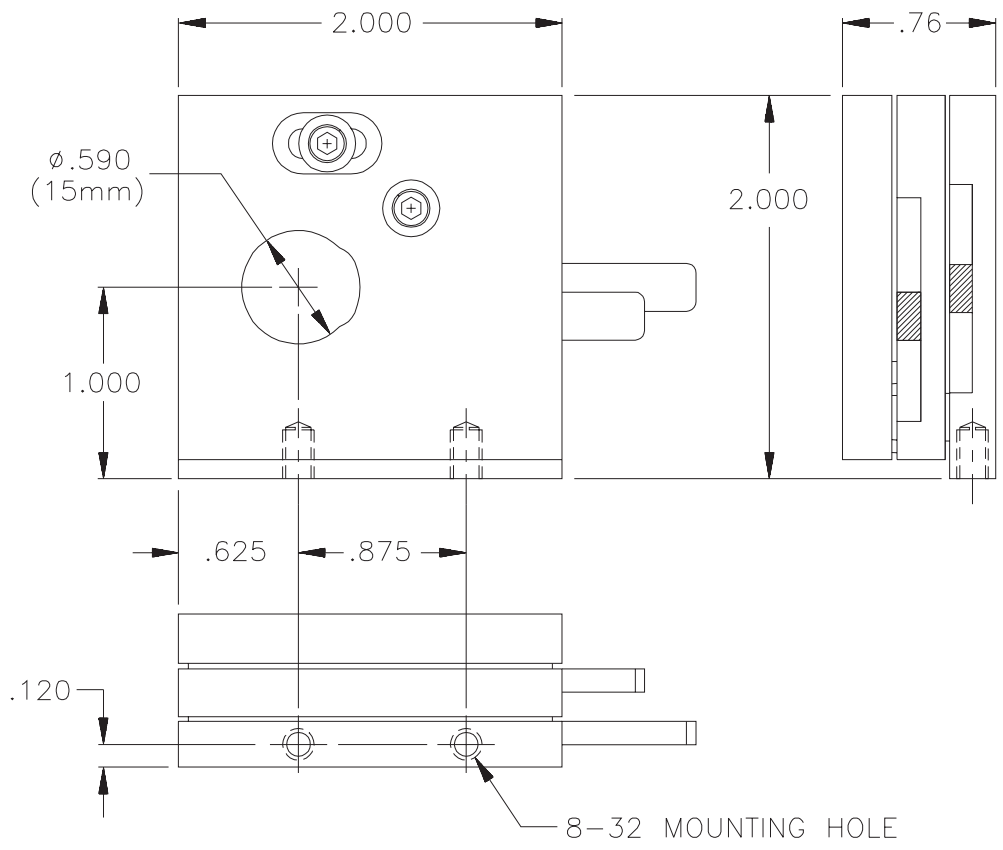

- 3. FINISH: BLACK ANODIZE
 - 2. MATERIAL: AL 6061-T6 OR EQUAL.
 - 1. DO NOT SCALE DRAWING
- NOTES: UNLESS OTHERWISE SPECIFIED

CLASSIFICATION PRODUCTION	
CONTRACT/FILEMANE 250-0015-000	
DRAWN BY RS	DATE 17SEP93
APPROVED BY	DATE
TOLERANCES (DIMENSIONS IN INCHES)	
X.X = ±0.05	
X.XX = ±0.01	
X.XXX = ±0.005	
X.XXXX = ±0.0005	
ANGLE ±0.5 DEGREES	

OPTIMA PRECISION INC.

XY Translator, Ø15mm

A	FMSC NO	DRAWING NO	REV
		250-0015-000	-
SCALE 1x	05AUG01	SHEET 1 OF 1	